



KOHLER

KOHLER

HYDRAULIC COMBO

DUMPER

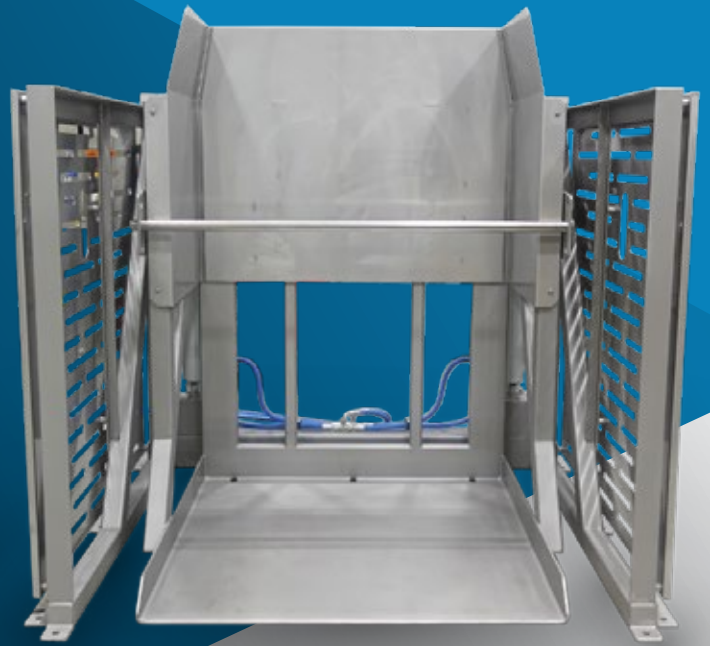

Give Your Production A Lift

REQUEST A QUOTE TODAY
402-465-8845 | kohlerindustries.com

GIVE YOUR PRODUCTION A **LIFT**

Budget friendly and built to order, the Kohler Combo Dumper is constructed for your needs. Simply stated, it provides the performance you expect from industrial food processing equipment.

The heavy-duty, stainless steel fabrication can lift 3,000 pounds of product, and tilt to dump between 60" to 115" or higher. The carriage can support all common container sizes, or be modified to suit. Further customize your carriage with straight or curved sides and your choice of adjustable or fixed restraining bar.

Grounded with multiple floor bolts, the cushioned valves reduce bouncing and shaking for smooth operation. Side guards alleviate pinch points as contents are dumped in a short cycle time, ensuring worker safety and efficiency.

A valued team workhorse, the Kohler Combo Dumper is constructed to handle long hours of heavy lifting, year after year. Our glass bead finish, stainless steel construction maintains sanitation standards while resisting wear from heavy use and frequent wash down.

With years of experience in the food processing equipment industry we understand the shortcomings of current equipment offerings. Our team has the flexibility to customize the equipment to your production needs. Allow our in-house team of engineers, fabricators, and consultants can construct a combo dumper to meet your exact requirements. Get started today.

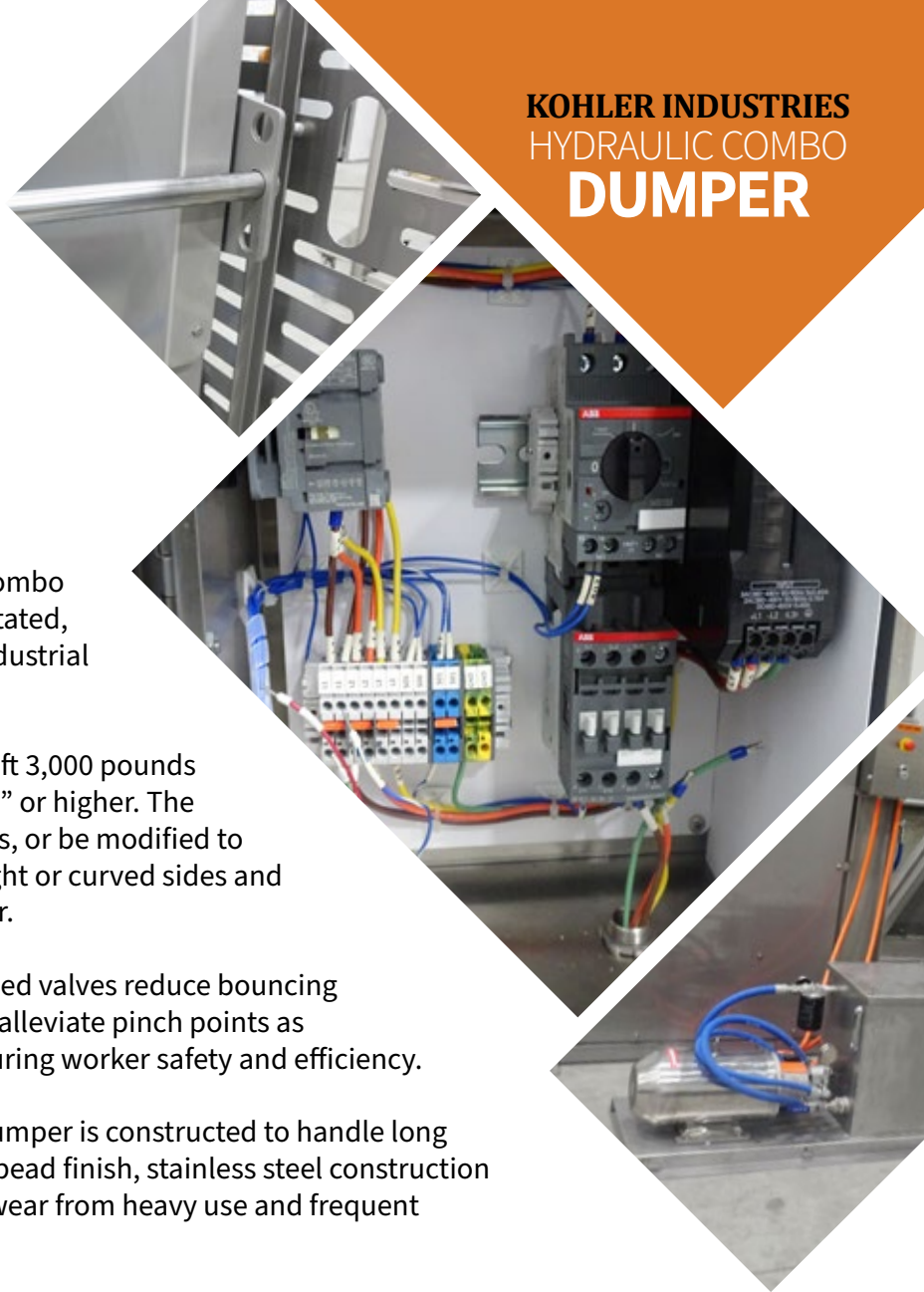

KOHLER INDUSTRIES
HYDRAULIC COMBO
DUMPER

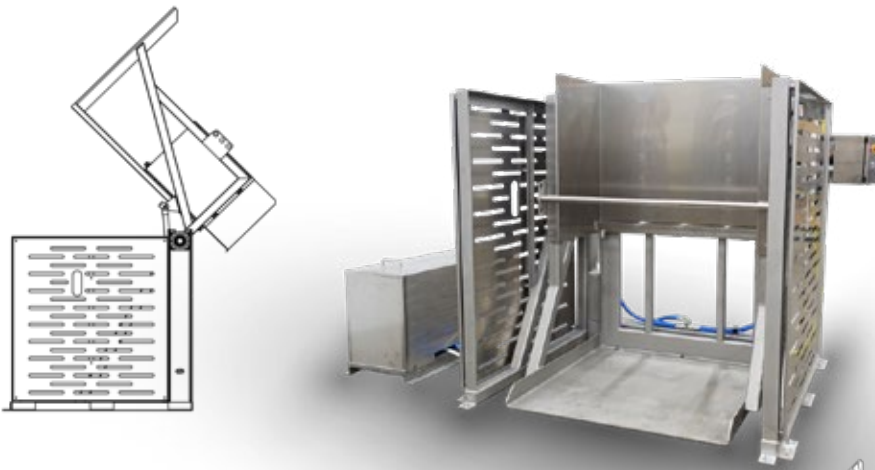

CUSTOMIZED CRAFTSMANSHIP

MATERIAL	304 stainless steel frame, plate, bar, chute, bearings, and cylinder pins. High lift model features solid framing (no hollow tube)
OPTIONS	Standard, pallet retract, high lift, buggy loading system
CAPACITY	3,000 lbs bin/vat standard. Options include buggy bracket or pallet retract
CARRIAGE	51"L x 48"W (or custom)
DISCHARGE	Built to order
DUMP ANGLE	45° angle
HOLD DOWN BAR	50", 52" or 54" fixed or adjustable
MOTOR	7.5HP, 480V, 3-Phase standard 10HP on High Lift model
DRIVE	Hydraulic power pack with cover
CONTROLS	Optional, built to order, UL listed
SAFETY	Safety guards (two or three side) light curtain optional
SANITATION	Easy washdown, clean design
OTHER	Custom built to your specifications by Kohler Industries, USA

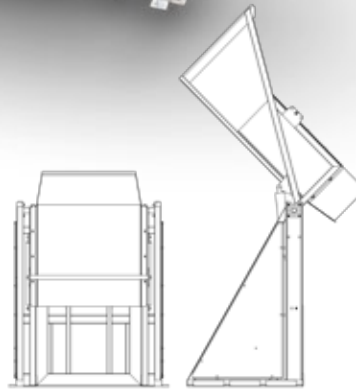

Our dedicated team works with you from start to finish. We listen to your production requirements and develop solutions for your unique needs.

New equipment from Kohler is simple and standardized; no proprietary parts here! Preventative maintenance and repairs are straightforward. Parts are typically on hand to reduce your downtime and keep your operation moving.

Designed for longevity, we build every machine to last. They simply won't quit. For this reason our machines retain value over time better than any other manufacturer.

REQUEST A QUOTE TODAY
402-465-8845 | kohlerindustries.com



Safety guards removed for photo. Never operate without provided safety guards.





LET'S TALK EFFICIENCY

At Kohler Industries, we think outside the combo dumper box. We address questions such as, “how can we increase plant efficiency, and also decrease the number of product touches?” We answer with customizations.

Pictured here are a few examples of just that. Quickly switch between large bins and smaller buggies. Divide a large bin into two smaller buggies. Funnel your load to further processing with pin-point precision. Dump the load onto a table for sorting. And more.

When you partner with Kohler Industries, you receive fully customized equipment. From start to finish, our equipment is durable, affordable, easy to operate, and most importantly – it brings efficiency to your processing needs.



REQUEST A QUOTE TODAY
402-465-8845 | kohlerindustries.com

WHY KOHLER INDUSTRIES? **LIFTED PERFORMANCE**

CUSTOM SPECS

Your product is unique. It's only natural your equipment be too. Our in-house design and assembly teams tailor-build all machines to your needs.

QUICK DELIVERY

Our 33,000 sq. ft. facility allows for fast turnaround on new equipment. We work hard with precision and speed to ensure a quick delivery.

IN STOCK PARTS

We keep the parts you depend upon in stock, ready to ship. This reduces your downtime and keeps your operation running smoothly.

CUSTOMER SERVICE

We are here for you. Speak with a real person when you call. We'll provide world class customer service and support to your team.

EXPERIENCE

With over 100 years of combined industry wisdom, put our expertise to the test. Let us show you what's possible in your equipment.

MADE IN USA

Born in the Midwest, all our equipment is made in the USA to ensure top quality. We oversee every aspect of production.



KOHLER INDUSTRIES
HYDRAULIC COMBO
DUMPER



Kohler Industries Inc.
4925 N 56 ST
Lincoln NE 68504

(402) 465 8845
www.kohlerindustries.com
sales@kohlerindustries.com